

Diesel Fuel Shutoff Valve SV Series

The SV series valve, which is solenoid operated, is a normally closed valve that opens when current is supplied from the battery through a magnetic switch. Temperature, level or pressure Switchgag[®] instruments installed on the diesel engine and pump or compressor trip the magnetic switch breaking the circuit from the battery which closes the valve and stops the engine.

The SV-12 valve operates on 12-VDC, has a 1/4 NPT inlet and outlet and a full 3/16 in. (5 mm) orifice. A 24-VDC (SV-24) is optional. The SV valves open against 30 psi. (207 kPa) [2.07 bar] inlet pressure.

For a greater flow rate valve, we offer the special series SV valve with a 1/4 in. (6 mm) orifice which opens against maximum pressure of 15 psi (103 kPa) [1.03 bar]. This valve is recommended where greater flow is required and only static head or low transfer pump pressures are encountered.

The Murphy SV-HP series valves open against diesel fuel transfer pump pressure up to 60 psi (414 kPa) [4.14 bar]. Models are available for 12- or 24-volt DC systems. The orifice is 1/4 in. (6 mm) using the same inlet/outlet and options as standard SV.

The SV Series fuel shutoff valve is for use with diesel engines with externally accessible fuel injection pumps. The volume of fuel required for the engine to operate must be able to pass through the 3/16 in. (5 mm) or 1/4 in. (6 mm) orifice of the valve. You must be able to attach the fuel valve directly onto or in close proximity to the fuel injection pump in order to close off fuel flow to the pump.

The SV series is **NOT** intended for use with engines having unit injectors or distributor type injection pumps. Use only with diesel.



Auxiliary Fuel Valves

Fuel Return Line Check Valve

The CKV series is an in-line, one-way valve for the prevention of fuel siphoning from the diesel return line by an injection pump. In engine shutdown

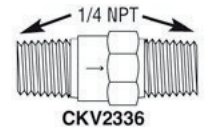

systems using a Murphy SV valve, the CKV is necessary to ensure a rapid shutdown of the engine by fuel starvation of the injection system. For details see bulletin 7867.

Fuel Line Pressure Relief Valve

The PRV50 is an in-line, one-way valve for the prevention of overpressure damage to fuel filters and their housings. This pressure relief valve operates in conjunction with a Murphy SV series shutdown valve. After the SV closes,

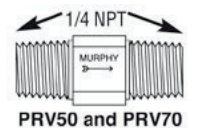

a rapid high pressure build-up caused by the fuel pump can occur. The PRV, mounted in a fuel return line after the filter, will open to relieve pressure buildup.

Specifications

Electrical Rating: 12- or 24-VDC, 10 watts

Orifice: 3/16 in. (5 mm) diameter (optional 1/4 in. [6 mm] diameter). See chart below. **Body Connections:** 1/4 NPT inlet/outlet

Maximum Opening Pressure:

3/16 in. (5 mm) orifice: 30 psi (207 kPa) [2.07 bar]

1/4 in. (6 mm) orifice: 15 psi (103 kPa) [1.03 bar]

Shipping Weight: 1 lb. 6 oz. (0.68 kg)

Shipping Dimension: 3 x 2-3/4 x 2-3/4 in. (76 x 70 x 70 mm)

SV-HP (High Pressure model)

Orifice: 1/4 in. (6 mm) diameter. See chart below.

Maximum Opening Pressure: 60 psi (414 kPa) [4.14 bar].

Differential Pressure	3/16 Orifice						1/4 Orifice				
	1	2	5	10	20	30	1	2	5	10	15
Gallons per Minute	.48	.68	1.1	1.5	2.2	2.6	.72	1.05	1.65	2.35	2.70
Liters per Minute	2.01	2.85	4.62	6.3	9.24	10.92	3.02	4.41	6.93	9.87	11.34

Typical SV Valve Installation

Installation and Service Suggestions

1. Make sure the valve is the same voltage as the battery. Under continuous duty, the coil will normally be hot; however, incorrect voltage can cause smoking and burned coils.
2. The valve will not operate if the flow arrow on the side of the valve does not indicate the correct direction of flow.
3. Do not apply pipe dope to female valve threads. Dope inside the valve will foul the seat and prevent proper seal.
4. Install the valve as close as possible to the injection pump.

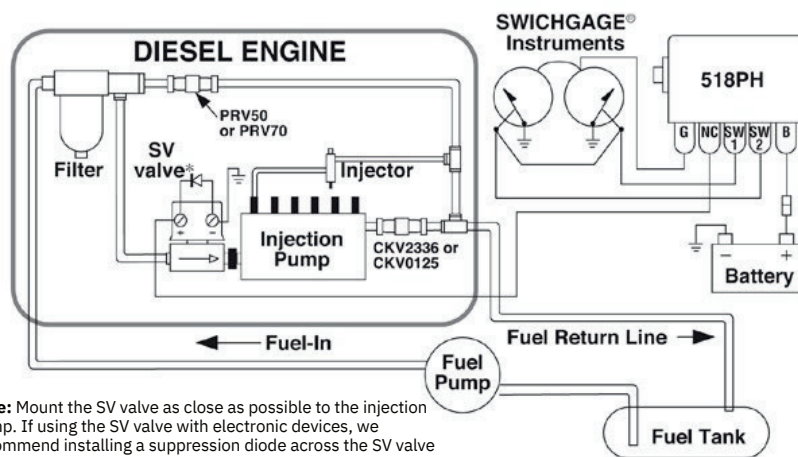

Note: Mount the SV valve as close as possible to the injection pump. If using the SV valve with electronic devices, we recommend installing a suppression diode across the SV valve coil.

Dimensions

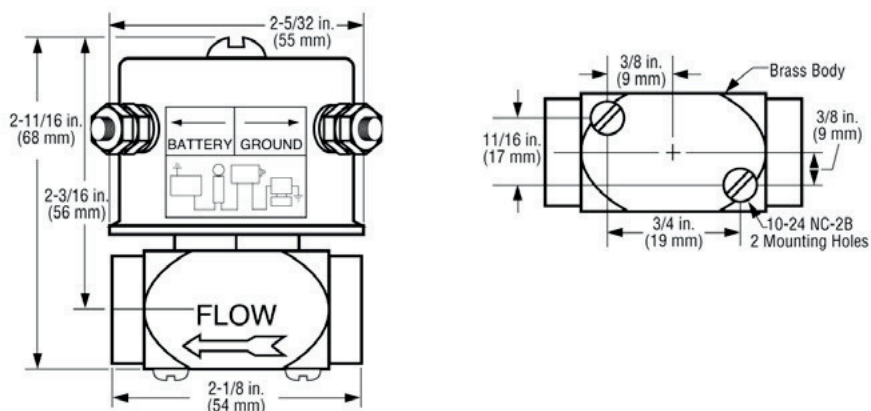

Troubleshooting the SV Series Valves

Check Control Circuit: To determine if the electrical system is energizing the solenoid, listen for a metallic click signifying the solenoid is operating. Absence of the click indicates loss of power supply. Check for blown or loose fuses, for an open circuit or a grounded coil, for broken lead wires or open splice connections.

Coil Burnout: Check for open-circuit coil. Replace coil if necessary.

High or Low Voltage: Check voltage across the coil with a voltmeter. Voltage must be in 85 percent to 110 percent of nameplate rating.

Incorrect Pressure: Check fuel line pressure. Pressure on the valve must be within the specific range of the SV in use.

Fuel Leak Through Valve: Disassemble the valve and clean parts. Replace any parts that are worn or damaged (see How To Order for repair parts).

Slow Shutdown: Due to the internal fuel capacity of some injection pumps, engine shutdown will not occur until that fuel is used up

Note: If engine continues to run after the valve closes, install a check valve such as CKV2336 in the return line.

How To Order

Options listed at right. All configurations may not be available. Call your sales representative or Enovation Controls for more information.

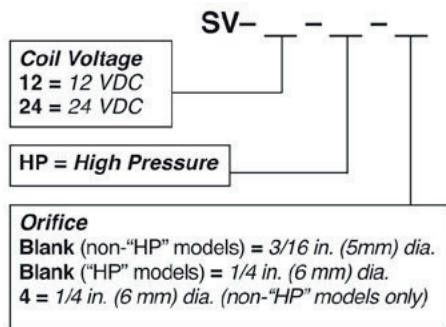

Part Number	Description	Notes
80-04-1412	Screw	Repair Parts
55010141	Coil Replacement 12-volt kit	
55010145	Coil Replacement 24-volt kit	
55010155	Core Repair Kit (Std. model)	
55010156	Core Repair Kit (HP model)	
55050194	Valve Body: 3/16 Orifice 1/4 NPT x 1/4 NPT (std.)	
55050193	Valve Body: 1/4 Orifice 1/4 NPT x 1/4 NPT	

SALES CONTACT

ENOVATION
CONTROLS®

CONTACT

sales@rajkotmarinellc.ae
+971 6 7487580
www.rajkotmarine.com

RAJKOT MARINE LLC

Jerf Industrial Area 1,
P.O Box 5861
Ajman, UAE

